

THE FIRST LEGO LEAGUE TABLE

IMPORTANT CHANGES STARTING IN 2001

1) Each year a 93" by 45" pre-printed Field Mat will come in your FLL kit and roll out to form your official playing field surface. This eliminates the need for a special surface on your table. In fact, you may simply decide to place your Field Mat and Field Borders right on a smooth floor.

If you already have an FLL table, or if you want to place your Playing Field right on a smooth floor, all you need is a new framework of Field Borders, as shown in Figure 2. Make it from two-by-fours, and paint it black.

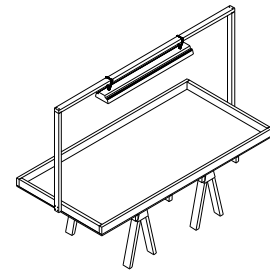

2) Tournament lighting has been standardized and is specified to be a 48" fluorescent shop light with (2) 40-watt tubes, hung approximately 48" from the Field Mat.

MATERIALS

Material	Quantity (with light)	Quantity (no light)
plywood, 96" X 48" X 1/2" or thicker	1	1
two-by-four, 8'	3	3
two-by-three, 8'	3	2
two-by-three, 10'	1	N/A
black paint	1 pt. or spray can	1 pt. or spray can
coarse drywall screws, 6 X 2-1/2"	1/2 lb.	1/2 lb.
Saw horse (kit), approx. 30" high and approx. 36" wide	2	2
48" fluorescent shop light w/(2) 40-watt tubes	1	N/A

TOOLS

safety goggles
cross cut saw
Phillips-head screw driver (power preferable)
tape measure & pencil
two 6" clamps
level
paint brush (unless you're using a spray can)

PARTS

Part	Make From	Dimensions	Paint	Quantity (with light)	Quantity (no light)
table surface	plywood	96" X 48"	no	1	1
large Field Border	two-by-four	96"	yes	2	2
small Field Border	two-by-four	45"	yes	2	2
Stiffener	two-by-three	48"	no	4	4
upright	two-by-three	48"	yes	2	N/A
cross beam	two-by-three	99"	yes	1	N/A
saw horse	kit	H \approx 30" W \approx 36"	no	2	2

Assembly

Step 1) Decide which face of the plywood is least smooth, and consider that the bottom face. On the bottom face, locate, clamp, and screw on the stiffeners as shown in Figure 1.

Step 2) On the top face of the plywood, locate and clamp the framework of Field Borders around the perimeter as shown in Figure 2. Double check that the 93" and 45" wall-to-wall inside distances are within $\pm 1/8"$ and trim or gap as needed until the tolerance is achieved. Then screw on the borders.

Step 3) Place the saw horses under the table and screw them on, located approximately as shown in Figure 3.

Step 4) The table is not designed to support the weight of a person---**DO NOT STAND ON THE TABLE.** Center, clamp, level, and screw the uprights onto the outside face of the small Field Borders as shown in Figure 4. Be sure each joint is strong. With the help of another person, situate the cross beam on top of the two uprights and screw it down. Hang the shop light by its chains from the center of the cross beam.

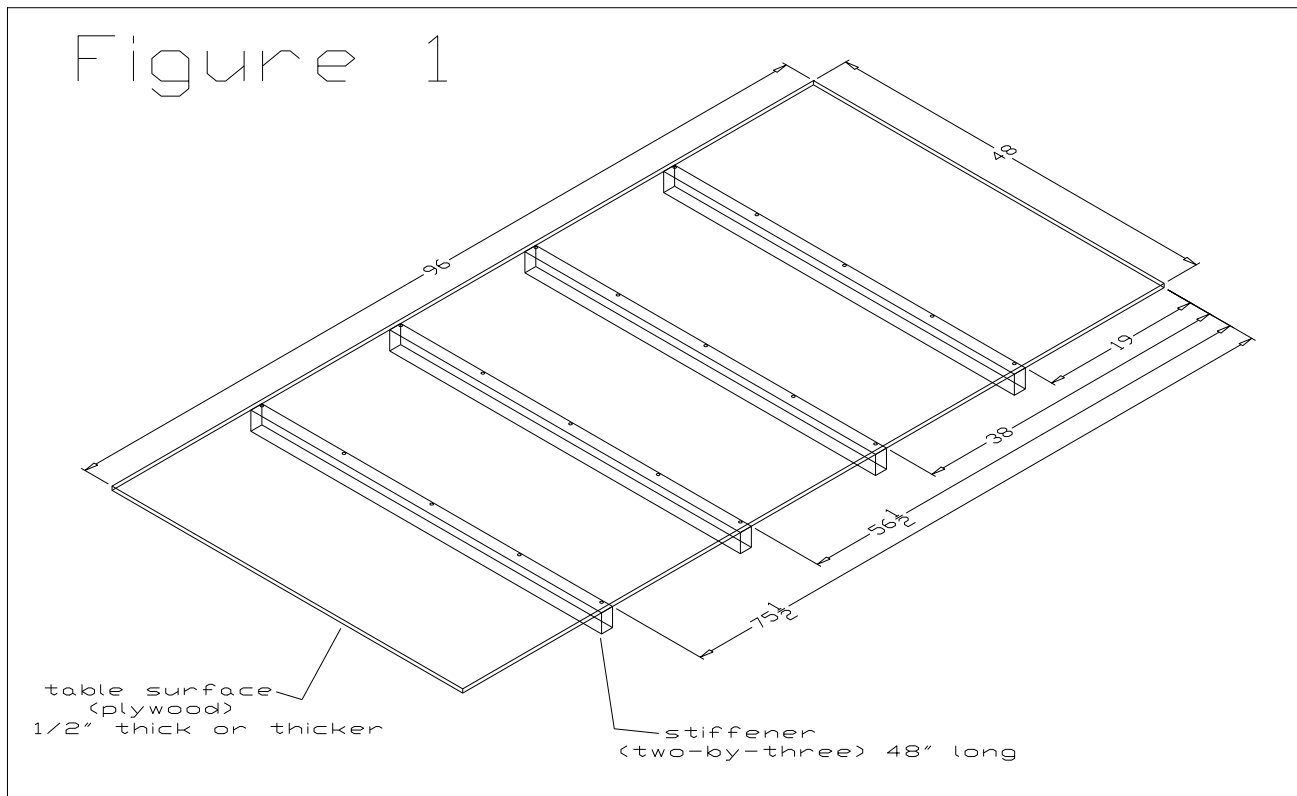

This diagram indicates the standard 1/2" plywood playing surface. Also, if the stiffeners are cut 1 1/2 inch short on each end, then there is room for the stiffeners of an upper table to nest into a lower table. This can be important if you're going to move more than one table at once – like at a tournament. Your tournament committee may ask to borrow your table for tournament practice tables, and this construction feature would facilitate the use of your table for tournament purposes. Overall length of the stiffeners would therefore be 45".

Thanks to Courtney G., Poudre Lego League, Ft. Collins Colorado.

Figure 2

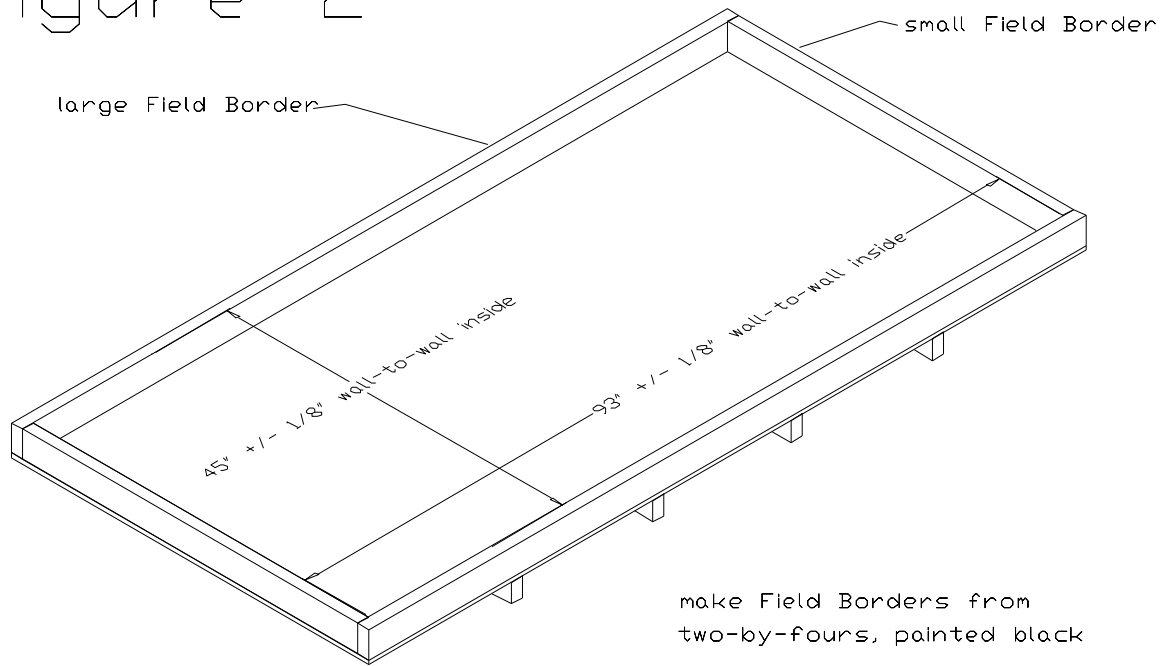

Figure 3

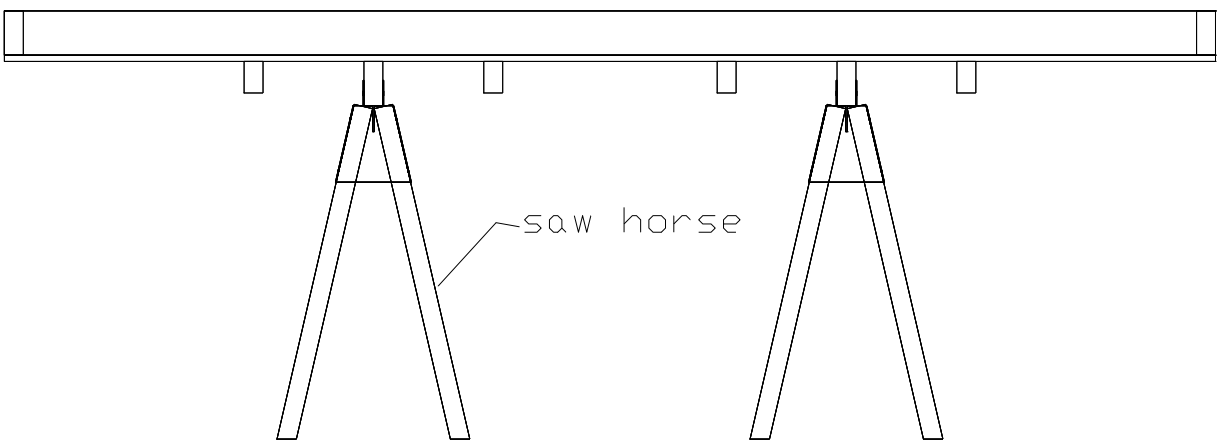

Figure 4

48" fluorescent shop light
w/(2) 40-watt tubes

cross beam
(two-by-three) 99" long

upright
(two-by-three) 48" long

